

Excellent Clamping

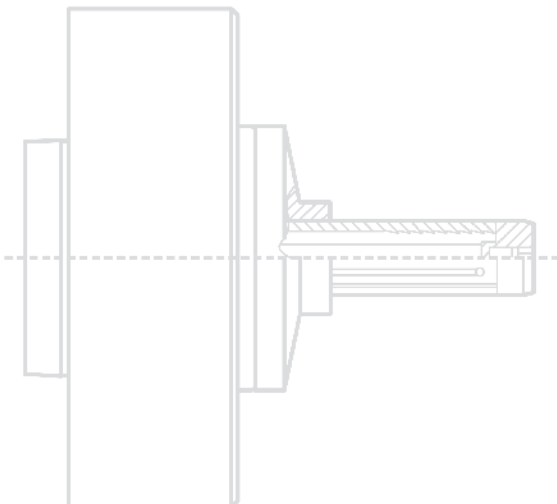

Mechanical Clamping Devices

Precise Mechanical Clamping Devices for All Requirements

Experience in clamping technology

For decades, König-mtm has been one of the leading manufacturers of state-of-the-art high-precision clamping devices.

The extensive production program covers clamping tools such as mandrels and chucks in hydraulic, mechanical or hydro-mechanical versions.

Clamping tools for market leaders

König-mtm's clamping chucks and the Königdorn® are well known in the tool industry and are well established as original equipment on top-class high-precision CNC controlled machine tools.

Mechanical clamping tools made by König-mtm

For today's machine tools the complexity of machining tasks, the variety of workpieces and accordingly the number of clamping tools are increasing permanently.

Resulting from substantial experience in clamping technology König-mtm is developing tailor-made mechanical clamping tools, that cover a wide range of workpiece geometries by means of high loading clearances.

This high workpiece flexibility leads to reduced tooling expenses and higher productivity, meeting the basic requirement of more efficient machining operations.

We would be pleased to design and produce your tailor-made clamping tool, according to your specific requirements.

The following pages introduce some examples of clamping tools of our production. For a better representation of function we show graphical drawings.

Colour code of clamping tool drawings

	Grey Königdorn®
	Blue/Light blue Königdorn® tooling (sectioned)
	Yellow Clamping areas of tooling
	Red Workpiece (partially sectioned)
	Green Base machine component

Advantages

- High loading clearances
- Reduced tooling set-up expense, high productivity (high workpiece flexibility)
- Short clamping lengths
- High workpiece tolerances possible
- Run-out accuracies up to 0,003 mm attainable
- High lateral rigidity due to flat-face contact of the workpiece
- High torque transmission
- Symmetrical expansion of clamping collet
- Quick change-over to other clamping diameters possible

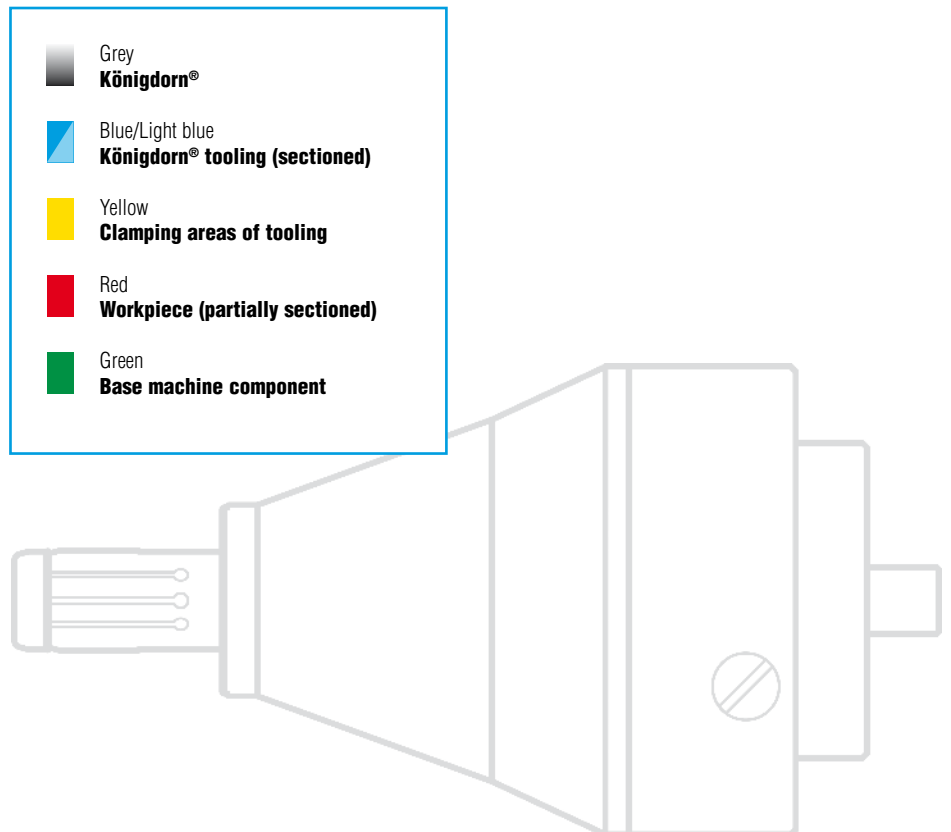

The Function Principle of Multi-Taper Clamping Tools

Multi-taper clamping tools are the best choice in case of greater tolerances and more loading clearance

In the automated process the demand for high loading clearance intends to cover a maximum part range without retooling.

The function principle of multi-taper tools allows higher loading clearances than conventional hydraulic expansion tools.

The clamping sleeve is mounted on the base body. Due to a special thread profile and axial force the clamping sleeve moves axially. The result is a fully cylindrical expansion which leads to workpiece clamping. Depending on the application and the clamping diameter, tolerances up to IT 13 can be obtained.

The cylindrical extension of a multi-taper clamping tool

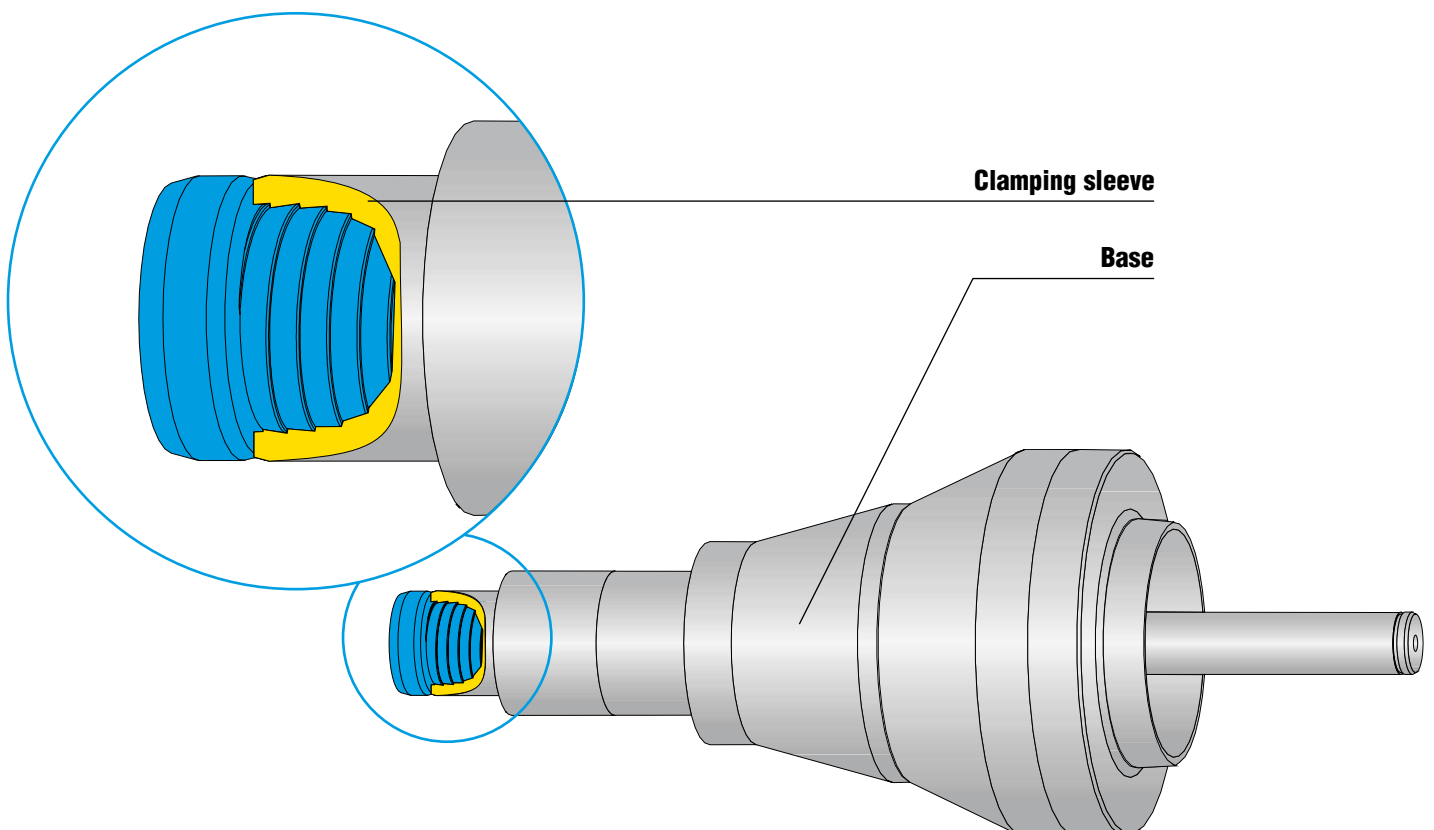
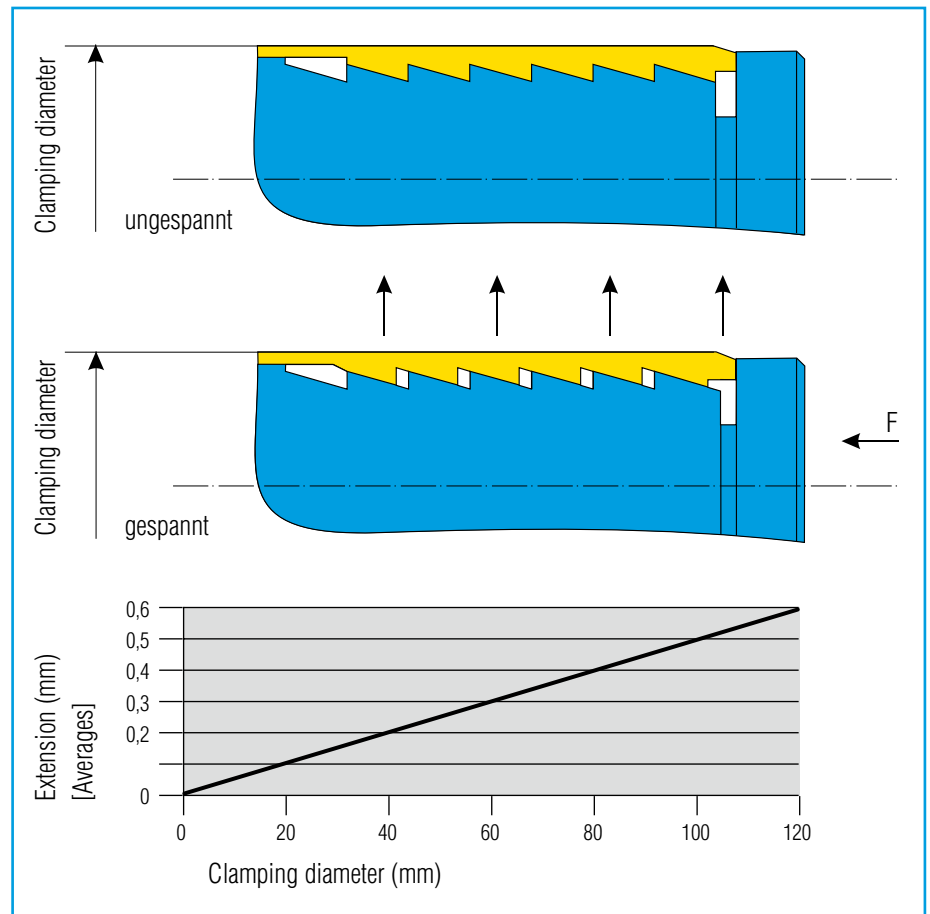

Mechanical Clamping Tools

Multi-Taper Clamping Tools

Multi-taper mandrel Type G1

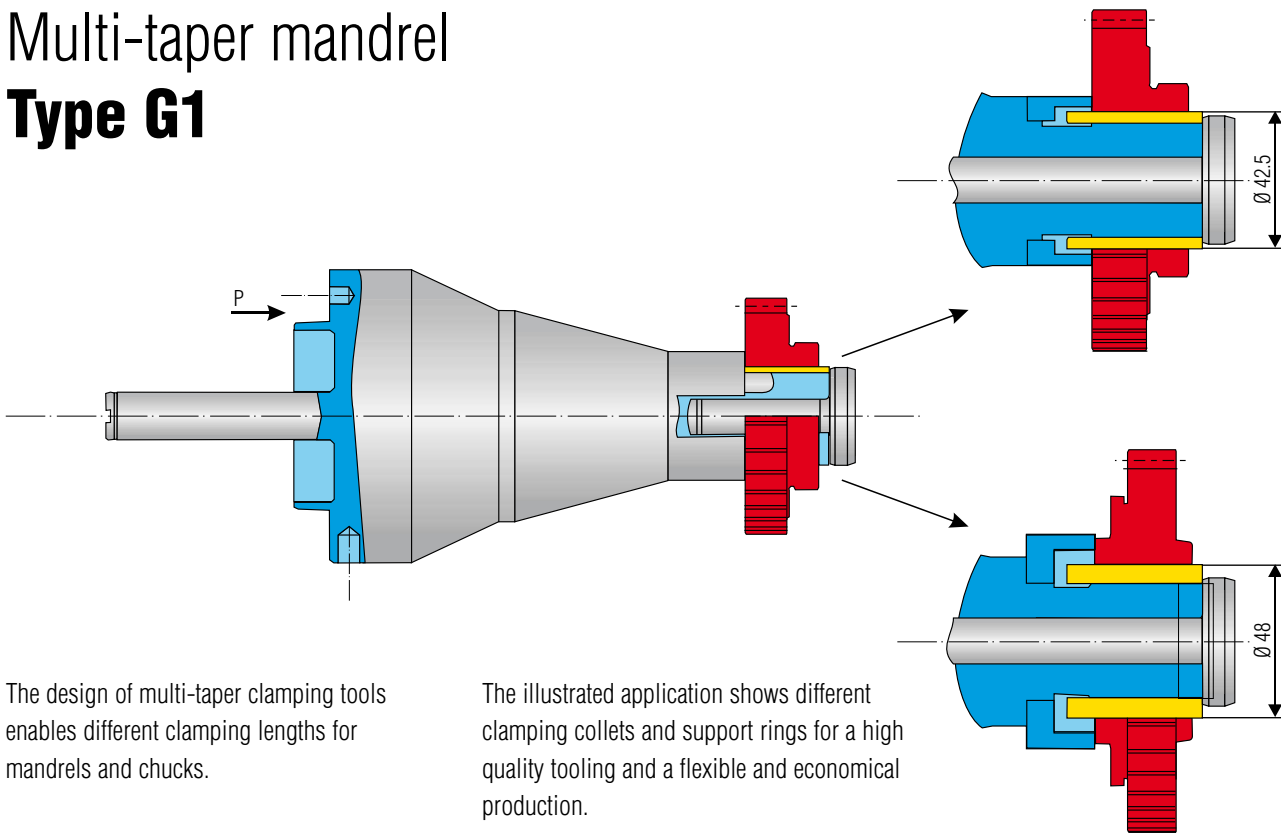

The design of multi-taper clamping tools enables different clamping lengths for mandrels and chucks.

The illustrated application shows different clamping collets and support rings for a high quality tooling and a flexible and economical production.

Multi-taper chuck Type G4

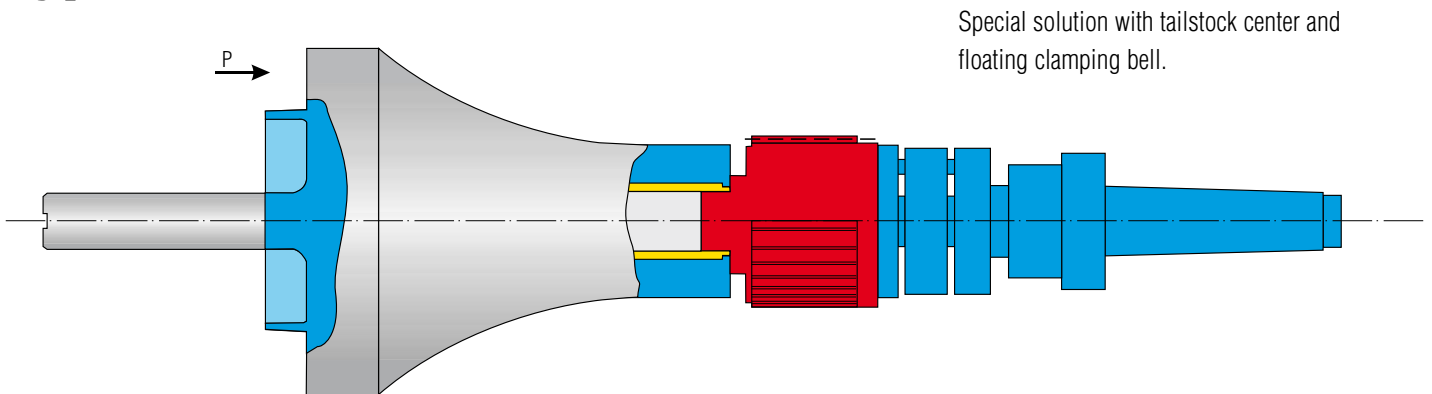

Special solution with tailstock center and floating clamping bell.

Mechanical Clamping Tools

Single-Taper Clamping Tools

Single-taper mandrels

Type M1

Clamping with single-taper and push rod

This mandrel is actuated by the push rod of the machine.

By means of integrated springs the Königsdorn® relaxes automatically.

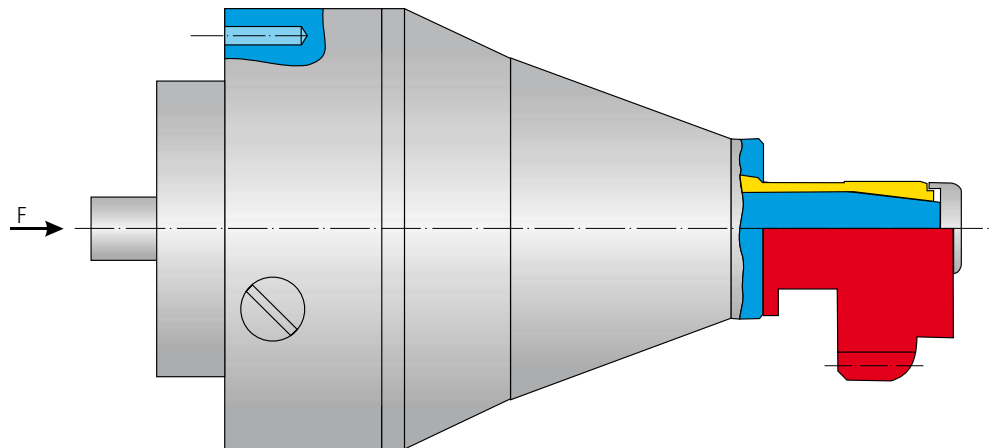

Clamping with single-taper and pull rod

Mechanical mandrel axially actuated by the pull rod of the machine.

- Changeable clamping sleeves ensure high flexibility
- Increases in torque transmission are achieved due to axial contact force

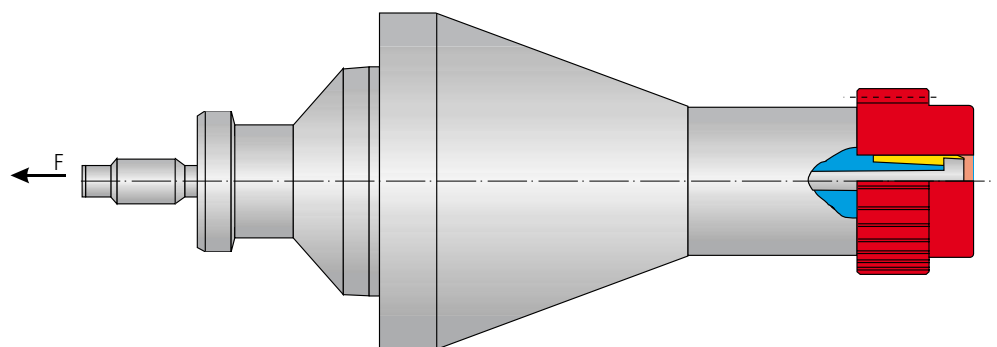

Mechanical Clamping Tools

Single-Taper Clamping Tools

Single-taper mandrel

Type M1

This solution is used for components with short clamping lengths and/or large diameters as well as for workpieces that require higher clearances for automatic loading.

The mandrel is directly mounted on the machine spindle and is actuated via the machine hydraulics. For clamping, a slotted collet will be expanded over the single taper. A secure process is guaranteed by additional holes for part present control.

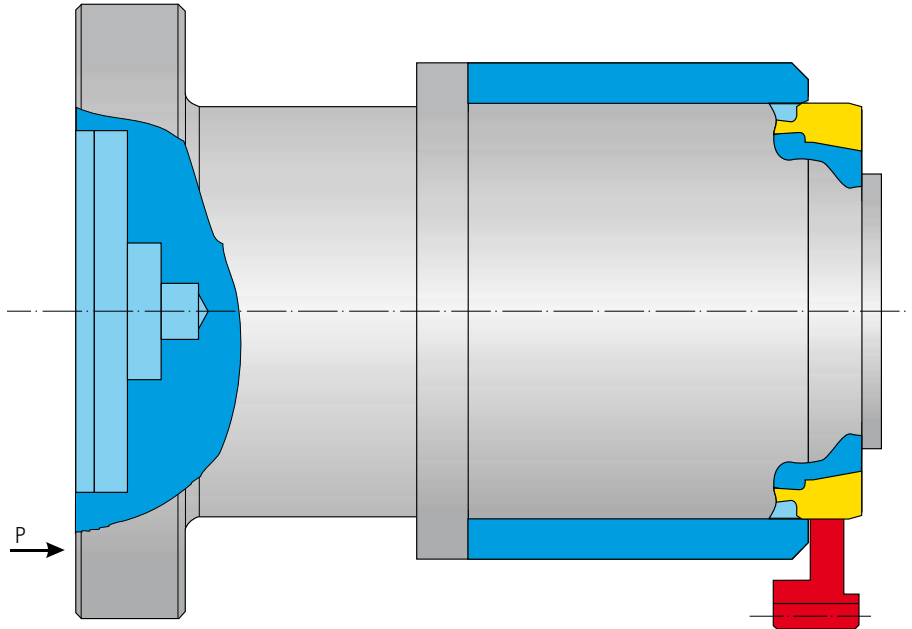

Single-taper chuck

Type M4

Example for a gear grinding application: mechanical Königsdorn® chuck for machining pinion shafts.

An internal center aligns the pinion shaft. The clamping function occurs by means of a tapered collet, activated by the machine hydraulics.

The additional use of a machine tailstock allows a perfect gear grinding operation.

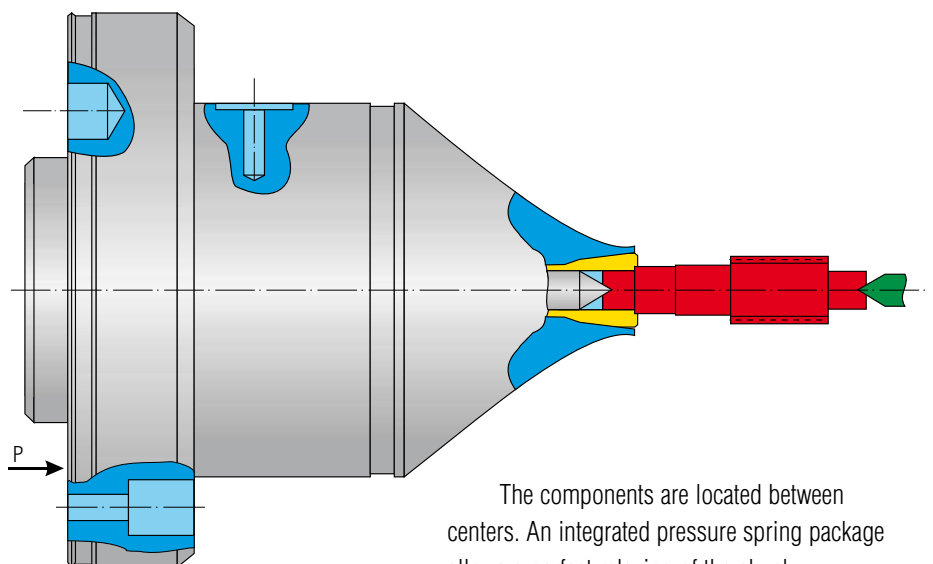

The components are located between centers. An integrated pressure spring package allows a perfect relaxing of the chuck.

Friction taper chuck Type M4

- High run-out accuracy
- Workpiece ejector available on request

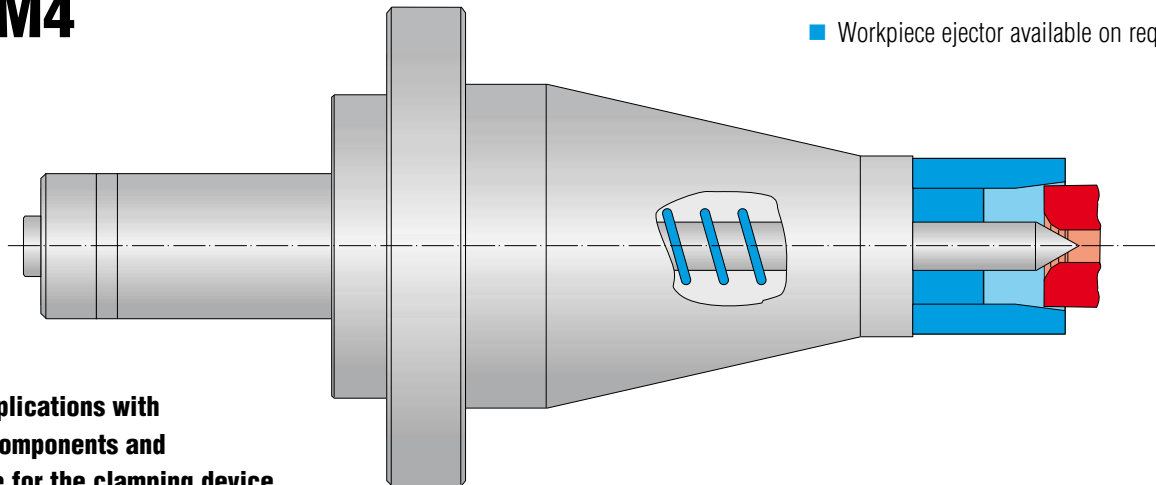

Chuck for applications with small shaft components and limited space for the clamping device

Quick and simple clamping is achieved by using a friction taper that provides sufficient torque transmission.

A live tailstock center is used to set the workpiece in the internal taper with sufficient force to achieve the required torque transmission capability.

Königdorn[®] clamping tools with zero-point quick-change system

König-mtm is presenting clamping tools with zero-point quick-change system. High-precision quick-change chucks based on the zero-point pallet system are combined with Königdorn[®] clamping tools (hydraulic or mechanical mandrels or chucks).

Zero-point clamping systems facilitate extremely fast and simple tool change with maximum precision.

The newly developed, extremely sturdy and deflection-resistant joint between the clamping tool and pallet achieves outstanding repeat accuracy in both radial and axial run-out and is thus ideally suited for a wide range of machining processes, e.g. turning and hobbing through to high-precision gear grinding.

The zero-point quick-change chuck is actuated pneumatically (automatically via machine tool or manually via blow gun). The Königdorn[®] clamping tool is operated via the machine tool's hydraulics (by push-rod or oil pressure).

- Ease of handling (no bolting-on)
- Maximum radial and axial run-out precision (repeat accuracy $\leq 3 \mu\text{m}$)
- Amenable to automation
- Minimal tooling effort/time
- High workpiece flexibility
- Improved productivity

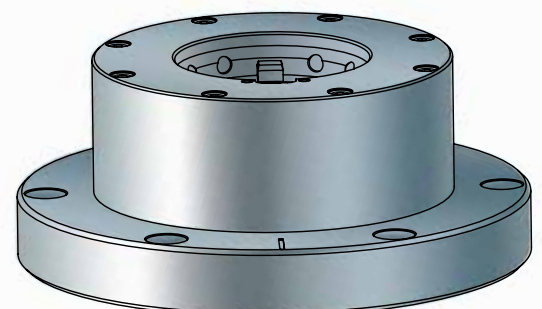
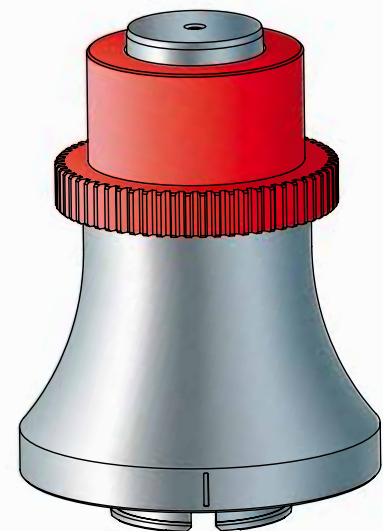



The König Group is located in Wertheim, the most northern town of Baden-Württemberg.

Lying on the confluence of the Main and Tauber rivers, the former seat court of the Count of Wertheim has a particular atmosphere with its ancient lanes, half-timbered houses and the castle ruin from the 12th century.



König-mtm GmbH, Spanntechnik

Postfach 14 63 · 97864 Wertheim
Am Stammholz 13 · 97877 Wertheim
Tel.: +49 (0) 93 42 8 76-0
Fax: +49 (0) 93 42 8 76-1 23
e-Mail: sales@koenig-mtm.de
www.koenig-mtm.de

Production Program

- Mechanical mandrels
- Hydraulic mandrels
- Mechanical chucks
- Hydraulic chucks
- Splined mandrels
- Light-weight mandrels
- Complete holding devices
- Electronic clamping pressure control
- Special mandrels
- Clamping mandrels for hobs
- Rotor milling devices
- Special collet chucks
- Special flanges
- Spindles

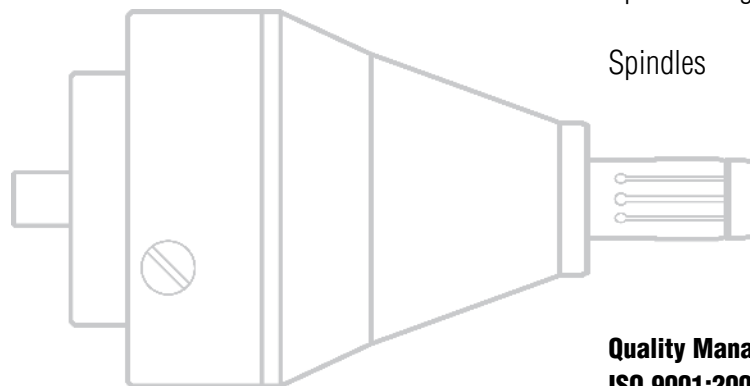

**Quality Management:
ISO 9001:2000 certified**

**Environment Management:
ISO 14001 certified**

© 2010 by König-mtm, Spanntechnik

Products and methods are subject to change without notice.